

Certified
**EXPLOSION
PROOF**

Certified by ETL to meet UL standards for Class I, Div 1 and 2, Group D and Class II, Div 1 and 2, Group F & G.



EXPLOSION PROOF SERIES



Accessory Package, 151510DEX-SP Includes: 10' x 1.5" ID Urethane, Static-Conductive Hose w/ Two 1.5" molded cuffs; Exclusive 16" Conductive Rubber Floor Tool w/ Replaceable Bristles and Squeegee; 54" Aluminum Two Piece Wand; 11" Aluminum Crevice Tool; 3" Round Static-Conductive Brush w/ Carbon Impregnated Nylon Bristles; 2" Button Lock Reducer x 1.5"

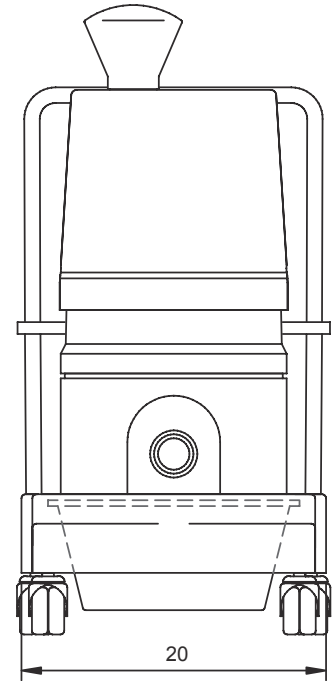
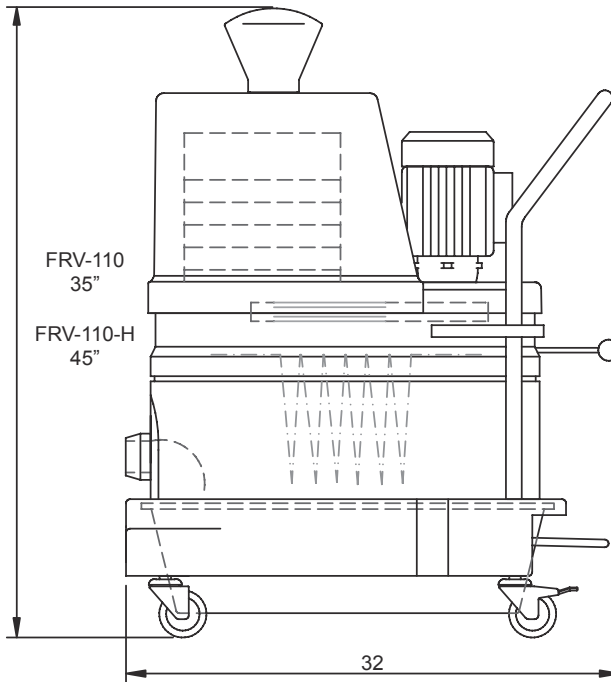

FRV 110 Standard Specifications

- DS1-EX1000 NRTL CERTIFIED EXPLOSION PROOF Motor & Switch, Class I, Class II
- 1.5 HP Motor, 110 Volt, 16 Amp, Single Phase, 60 Hz
- 13 ft² MicroClean BVSC Filter, Manual Shaker System
- 40 ft² HEPA Filter with Minihelic (optional)
- 2" (50mm) Inlet Connection with Bronze Cast Deflector
- Multi-Stage Centrifugal High Performance Turbine w/Relief Valve
- 9 Gallon, Foot Lever Actuated Dustpan
- Counterbalanced Base with 3" Heavy Duty Conductive Casters
- Compression Cast Composite Modular Housing
- Carbon Impregnated, Anti-Static 10⁻⁶ Ohms

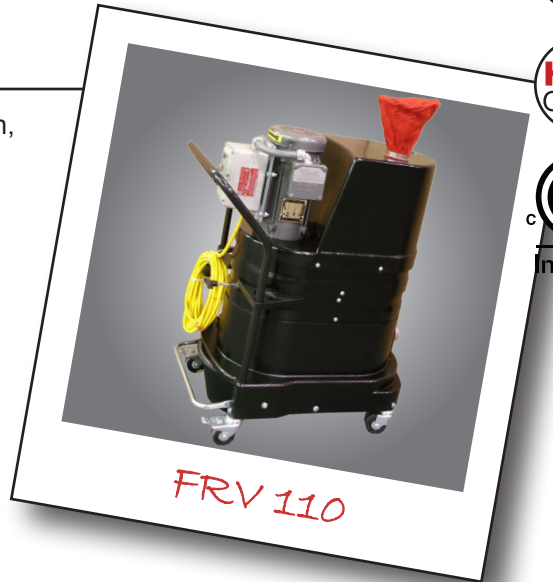

Base Price¹: FRV 110 - Call for Pricing

ADDER	DESCRIPTION
D	Explosion Proof HEPA Module ¹
24000	Static Conductive Disposable Dustpan Liner with Lid ^{ACC1}
1560OHDEX	Overhead Cleaning Accessory Kit ^{PKG}
-25	Optional - increase hose length to 25' ^{HOS2}
302120-EX	Extended Caster Frame Assembly w/Antistatic Casters ²
34878	Retractable Grounding Reel w/Stainless Steel Clamp ²

¹EX, ²ADD